

TPC PACKAGING
SOLUTIONS

TAPE Products Company

Automation Solutions



New Ideas. Valued Partner. Optimized Solutions.

1

Case Erecting

Flat cartons are automatically expanded and made ready for filling by case erecting equipment.



2

Case Packing

A free-arm robot is programmed to pack finished product into open cartons.

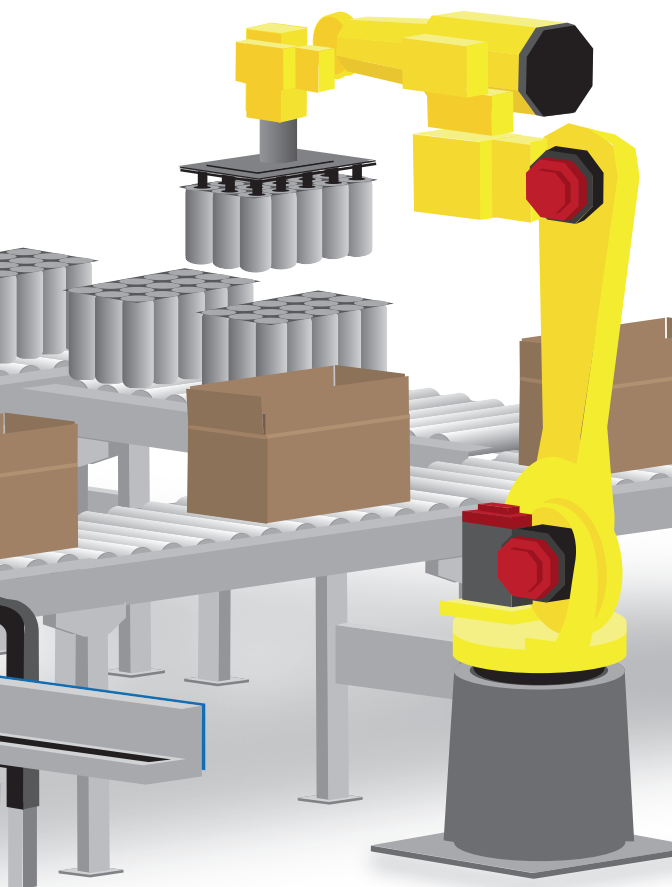

3

Carton/Case Sealing

Each filled carton is closed and securely sealed by carton/case sealing equipment. Unique carton shapes and sizes can be accommodated.

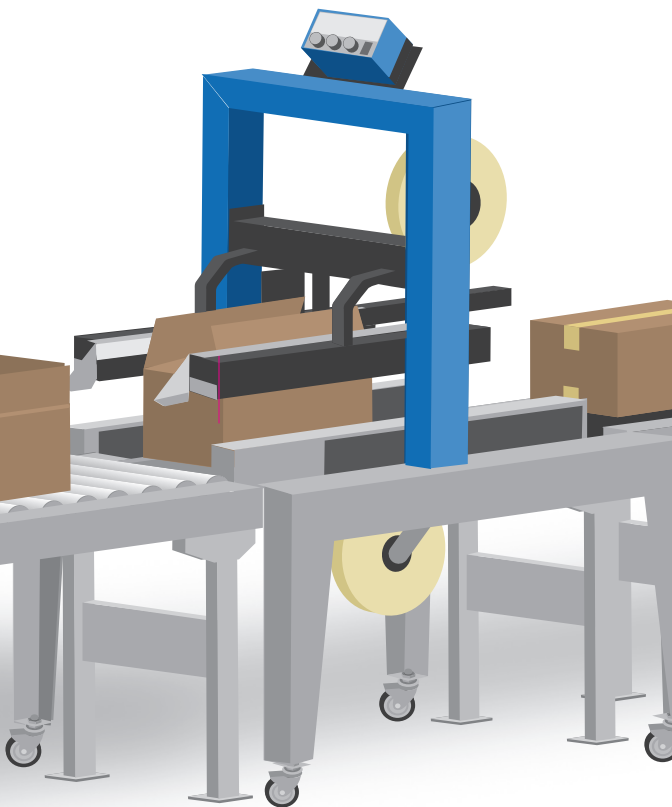

4

Inkjet Printing and Label Application

Each properly sealed carton is custom inkjet printed and labeled with automatic label application equipment.



5

Palletizing

A palletizing robot optimally loads each pallet with sealed and marked cartons.



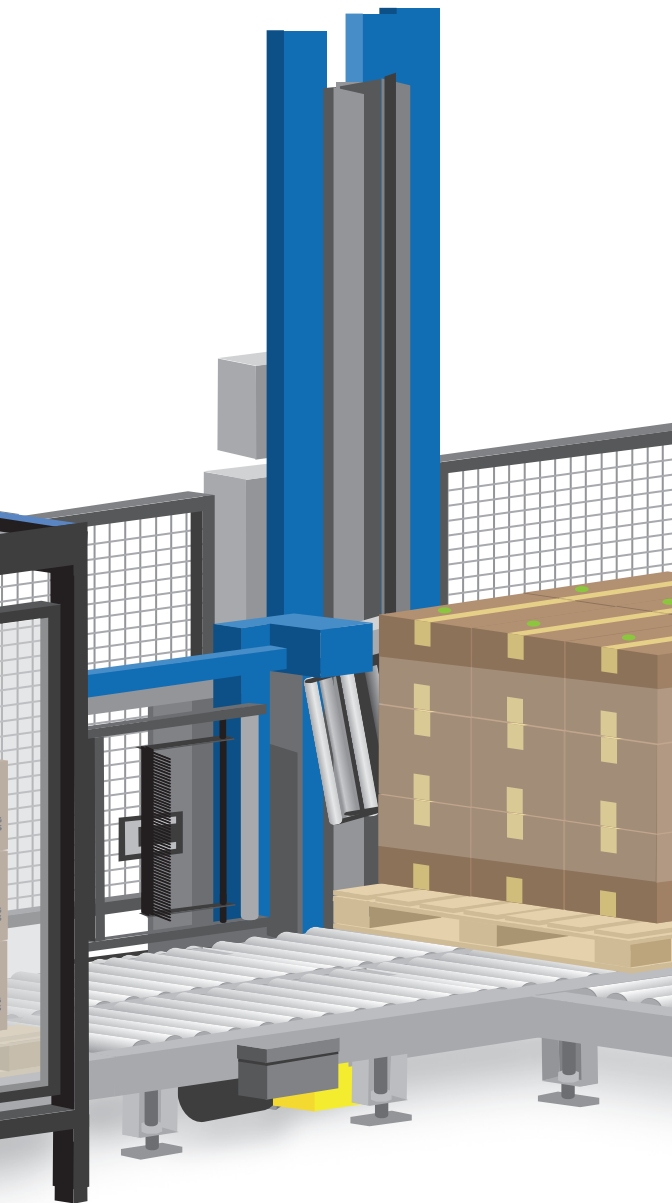

6

Pallet/Stretch Wrapping

A programmed stretch wrap machine provides a consistent wrap around your palletized product.

7

Pallet Labeling

Automated pallet applicators apply product information to the palletized product bundle. Finalized pallets are now ready for shipping or warehousing.



Benefits of Automated Packaging Systems

Better Ergonomics to Reduce Operator Strain

Often simple additions to systems already in place can improve ergonomics for operators, leading to better employee retention, improved morale, and less risk of injury.



Reduced Labor Cost

It is becoming increasingly difficult to staff positions that require repetitive manual tasks. Automating allows for less or little operator intervention. Our audit process will highlight opportunities to decrease labor, eliminate potential bottlenecks, and decrease downtime. We will provide a return on investment analysis to show the potential payback time frame.

Increased Production Speed

By automating it's possible to achieve greatly improved production speeds. This will allow for better throughput and overall cost advantages.

Packaging Line Audit

The need for improved production speeds, better ergonomics, and reduced labor are just some of the challenges facing manufacturing and distribution today. Our packaging line audit process allows for idea generation that can impact your end of line packaging process to deliver the results that are needed now and in the future.

Our specialist will review your process by performing time studies, material reviews, and a review of capacity on your existing production equipment to work with you to come up with the outcomes that will have the greatest impact on your goals.

After our audit, we will provide detailed reporting that consists of ROI information for packaging equipment capital expenditures, layout recommendations, material improvements, recommended preventative maintenance solutions for increased line up time, and many other optimized solutions.



Parts and Service and Maintenance Programs

As a full-service packaging company, our ability to partner with your business doesn't end with packaging equipment.



We have trained service technicians to assist you when needed.

Standard machines include a parts manual for easy ordering. Parts are readily available for prompt shipment.

We offer preventative maintenance programs and no cost wear parts bundled with material sales agreements that allow your maintenance team to focus on other areas of your business.

Packaging Materials

In addition to the equipment, we have all the consumables to support your needs:

Carton sealing tape, replacement tape heads, banding, ink cartridges, labels, thermal transfer labels, stretch film.

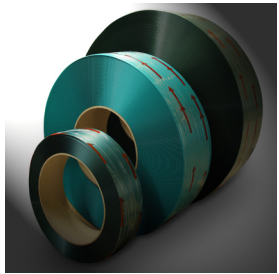

Manufacturers Represented



DEKKA®



ID TECHNOLOGY®





For more information about automation solutions, call or visit us online at tpcpack.com.

TPC PACKAGING SOLUTIONS
TAPE Products Company

tpcpack.com

Cincinnati
Regional Distribution Center/Corporate Offices

11630 Deerfield Rd, Cincinnati, Ohio 45242
1-800-543-4930

Chicago
Regional Distribution Center

1401 Davey Rd, Suite 800, Woodridge, Illinois 60517
1-800-543-4930

Orlando
Regional Distribution Center

7803 Southland Blvd, Suite 204, Orlando, Florida 32809
1-800-543-4930

Dallas/Forth Worth
Regional Distribution Center

901 Parkway Dr, Grand Prairie, Texas 75051
1-800-543-4930

New Ideas. Valued Partner. Optimized Solutions.